



# LIBRA<sup>pro</sup>

## online UPS

10-100 kVA three-phase / single-phase  
10-800 kVA three-phase / three-phase

- LOCAL AREA NETWORKS (LAN)
- INTERNET CENTERS (ISP/ASP/POP)
- ELECTRO-MEDICAL DEVICES

- SERVERS
- INDUSTRIAL PLCS
- TELECOMMUNICATION DEVICES

- DATA CENTERS
- EMERGENCY DEVICES (LIGHTS, ALARM)
- INDUSTRIAL APPLICATION

# LIBRA<sup>PRO</sup>

The **Libra Pro** series includes a power range from 10 to 100kVA threephase/singlephase and 10 to 800kVA threephase/threephase, using double conversion on-line technology (VFI) with inverter transformer based for output galvanic isolation. The load is powered continuously by the inverter with a filtered, stabilised and regulated sinewave supply. The input and output EMI filters considerably increase the immunity of the load to mains disturbances and surges.

The **standard Libra Pro** is designed with thyristor's rectifier 6Pulse up to 200kVA; the 12Pulse rectifier is available from 60 to 200kVA to improve the input current distortion performance, for the above the 12Pulse rectifier is standard.

The **Libra Pro IGBT** series is designed as low impact source solution, therefore with Power Factor Correction rectifier built with IGBT technology, available from 100 to 500kVA.

**Libra Pro** provides maximum protection for vital 'mission-critical' networks, security applications (electromedical) and industrial applications thanks to its outstanding mechanical and electrical design.

- isolation transformer on the inverter
- extremely high short-circuit current
- sinusoidal absorption  
(THDI% less than 3% for IGBT version)

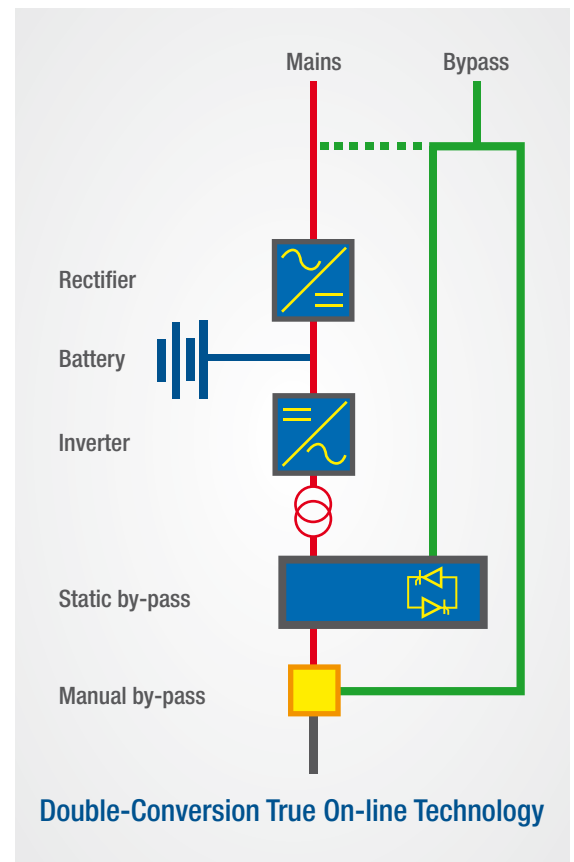

## Main Features

- Reliable, filtered, stabilised and regulated sinewave output (double conversion on-line technology VFI according to EN50091-3 specifications with filters for atmospheric disturbance suppression)
- High reliability: IGBT technology, full microprocessor control with no-break static and manual bypasses, extremely high short-circuit current to ensure compatibility with the most difficult applications (lighting, drives and industrial processes) and an isolation transformer on the inverter output
- Low impact on the mains supply: less than 3% input current distortion from 100 to 500kVA to prevent resonance problems for upstream applications. The distortion is unaffected by impedance or frequency, and allows economies when sizing power sources such as isolation transformers or generators for Libra Pro installations
- High level diagnostics: event log, states, measurements and alarms, available from the built-in LCD in several languages
- Selectable power walk-in allows to limit the input rushing current
- Maximum reliability and power availability (parallel up to 8 units for redundant (N+1) or parallel operation)
- EPO (Emergency Power Off) input for UPS shut-down using remote emergency button
- Front access
- Battery care system for Sealed, Wet, Ni-Cd battery type
- Back-feed protection fitted as standard

# SPECIFIC SOLUTIONS

Libra Pro can be adapted to your requirements. The operation mode is selectable by LCD display for various configurations:

- **Single operation**-online
- **Parallel operation** up to 8 units
- **Ecomode** for energy saving-offline
- **Smart Active**-Intelligent management for standby mode
- **Automatic Voltage Stabilizer** (without battery)
- **Frequency converter** (without battery)

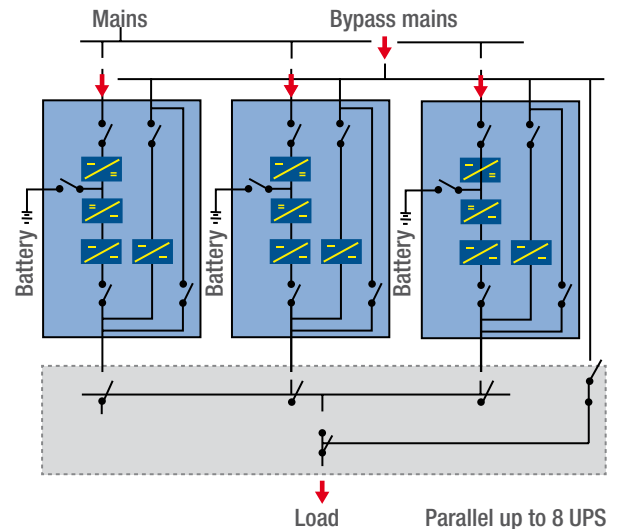

Please contact G-TEC Europe to discuss specific applications and options.

## Simplified Maintenance

Access for maintenance is entirely from the front of the unit. The power and electronic components are easily accessible for maintenance and repair work. This particular feature means that the MTTR (Mean Time To Repair) is typically less than 30 minutes. A large amount of maintenance information is available from the front mimic panel and LCD. In addition, system operating parameters are software configurable via a local PC to allow new functions to be added or adjustment made to operating specifications.

### Advanced Communication

- Compatible with TELEGUARD for remote maintenance
- Advanced, multi-platform communication, for all operating system and network environments: PowerShield2 supervision and shut-down software included, with SNMP agent, for Windows 95, 98, 2000, Me, XP, Mac OSx, 9.x, Linux, NT 4.0, Novell operating system. The UPS is equipped as standard with CD and cable for direct connection to the PC (Plug and Play).
- Can also provide shut-down software for: IBM AIX; Free BSD; BSDI UNIX; BSD/OS; Unixware; SCO Openserver; Solaris; SUN; DEC; Compaq True64; HP UNIX; SGI Irix MIPS; NCR UNIX.
- Double RS232 serial ports
- Network adapter slot for SNMP agent
- EPO (Emergency Power Off) shut down input contact
- SNMP card for Ethernet Network (optional)
- Remote LCD display panel (optional)
- Interfaces JBUS/ModBUS and ProfiBUS

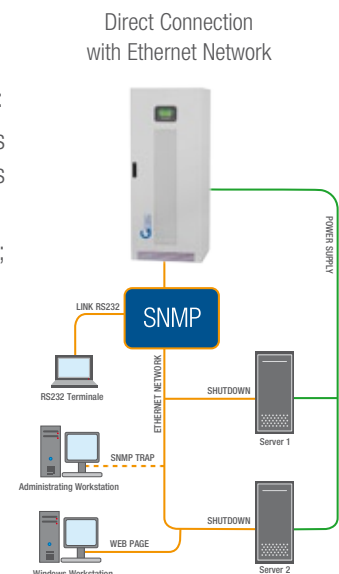

# LIBRA<sup>PRO</sup>

TECHNICAL SPECIFICATIONS								
Model	LB010MP <sup>(B)</sup>	LB015MP <sup>(B)</sup>	LB020MP <sup>(B)</sup>	LB030MP	LB040MP	LB060MP	LB080MP	LB100MP
Rated Power (kVA)	10	15	20	30	40	60	80	100
Efficiency	> 93% in AC/AC; up to 98% in Smart Active Mode							
Dimension (mm) LxDxH	555x740x1400					800x740x1400		800X 800X 1900
Weight (kg) w/o batteries	200	220	230	290	340	440	520	650
Colour	Light Gray RAL 7035 (or RAL7016 on request)							
Protection Rating	IP20							
Noise (dB at 1m)	54		62				63	
INPUT								
Rated Voltage	380-400-415Vac 3ph							
Voltage Tolerance	300 ÷ 480 Vac							
Frequency	45 ÷ 65 Hz							
Power walk-in	0 ÷ 100% in 30sec. (selectable)							
Frequency Tolerance	± 2% (selectable from 1% to 5%)							
Standard Features	Back Feed protection and splitted bypass line							
OUTPUT								
Power (kVA)	10	15	20	30	40	60	80	100
Active Power (kW)	9	13,5	18	27	36	54	72	90
Nominal Voltage (V)	220-230-240Vac 1phase							
Static Stability	± 1%							
Dynamic Stability	± 5% in 10msec							
Voltage Distortion	< 1% at linear load / < 3% at non-linear load							
Crest Factor	3:1							
Frequency stability on battery mode	0.05%							
Frequency	50 - 60 Hz (selectable)							
Overload Control	110% for 60min.; 125% for 10min.; 150% for 1min.							
BATTERIES								
Type	Pb Selead acid, Wet, Ni-Cd							
Ripple	< 1%							
Temperature Compens.	-500mV x °C							
Typical charging current	0,2 x C10							
N. cells for Pb Batteries	192							198
COMMUNICATION								
Standard	Double RS232 ports with Monitoring Software CD; Dry contacts; 2 interface intellislots							
Remote Commands	EPO and INV. OFF							
Optional	SNMP card; JBUS/ModBUS converter RS485 port; ProfiBUS converter; Multilicence							
ENVIRONMENTAL								
Room Temperature	0 ÷ 40 °C							
Humidity	< 95% (non-condensing)							
Compliance	Standards LV 2006/95/EC - 2004/108/EC - Safety IEC EN 62040-1; EMC IEC EN 62040-2; Performance IEC EN 62040-3; VFI-SS-111 Classified as IEC 62040-3							

<sup>(B)</sup> Available also with internal batteries.

**Note:** product specifications are subject to change without further notice.

# LIBRA<sup>PRO</sup>

TECHNICAL SPECIFICATIONS							
Model	LB010TP <sup>(B)</sup>	LB015TP <sup>(B)</sup>	LB020TP <sup>(B)</sup>	LB030TP	LB040TP	LB060TP	LB080TP
Rated Power (kVA)	10	15	20	30	40	60	80
Efficiency	> 93% in AC/AC; up to 98% in Smart Active Mode						
Dimension (mm) LxDxH	555x740x1400					800x740x1400	
Weight (kg) w/o batteries	210	220	230	280	330	450	600
Colour	Light Gray RAL 7035 (or RAL7016 on request)						
Protection Rating	IP20						
Noise (dB at 1m)	54		60		62		
INPUT							
Rated Voltage	380-400-415Vac 3ph						
Voltage Tolerance	300 ÷ 480 Vac						
Frequency	45 ÷ 65 Hz						
Power walk-in	0 ÷ 100% in 30sec. (selectable)						
Frequency Tolerance	± 2% (selectable from 1% to 5%)						
Standard Features	Back Feed protection and splitted bypass line						
OUTPUT							
Power (kVA)	10	15	20	30	40	60	80
Active Power (kW)	9	13,5	18	27	36	54	72
Nominal Voltage (V)	380-400-415Vac 3phase						
Static Stability	± 1%						
Dynamic stability	± 5% in 10msec						
Voltage Distortion	< 1% at linear load / < 3% at non-linear load						
Crest Factor	3:1						
Frequency stability on battery mode	0.05%						
Frequency	50 - 60 Hz (selectable)						
Overload Control	110% for 60min.; 125% for 10min.; 150% for 1min.						
BATTERIES							
Type	Pb Selead acid, Wet, Ni-Cd						
Ripple	< 1%						
Temperature Compens.	-500mV x °C						
Typical charging current	0,2 x C10						
N. cells for Pb Batteries	192						
COMMUNICATION							
Standard	Double RS232 ports with Monitoring Software CD; Dry contacts; 2 interface intellislots						
Remote Commands	EPO and INV. OFF						
Optional	SNMP card; JBUS/ModBUS converter RS485 port; ProfiBUS converter; Multilicence						
ENVIRONMENTAL							
Room Temperature	0 ÷ 40 °C						
Humidity	< 95% (non-condensing)						
Compliance	Standards LV 2006/95/EC - 2004/108/EC - Safety IEC EN 62040-1; EMC IEC EN 62040-2; Performance IEC EN 62040-3; VFI-SS-111 Classified as IEC 62040-3						

<sup>(B)</sup> Available also with internal batteries

**Note:** product specifications are subject to change without further notice.

# LIBRA<sup>PRO</sup>

TECHNICAL SPECIFICATIONS								
Model	LB100GBT	LB120IGBT	LB160IGBT	LB200IGBT	LB250IGBT	LB300IGBT	LB400IGBT	LB500IGBT
Rated power (kVA)	100	120	160	200	250	300	400	500
Efficiency	> 93% in AC/AC; up to 98,5% in Smart Active Mode							
Dimension (mm) LxDxH	800x850x1900		1000x850x1900			1500x1000x1900		2100x 1000x 1900
Weight (kg) w/o batteries	660	700	800	910	1000	1400	1700	2100
Colour	Light Gray RAL 7035 (or RAL7016 on request)							
Protection Rating	IP20							
Noise (dB at 1m)	63 ÷ 68				70 ÷ 72			
INPUT								
Rated Voltage	380-400-415Vac 3ph							
Voltage Tolerance	300 ÷ 480 Vac							
Frequency	45 ÷ 65 Hz							
Power Factor	> 0,99							
Current Distortion	< 3% THDi%							
Power walk-in	0 ÷ 100% in 30sec. (selectable)							
Frequency Tolerance	± 2% (selectable from 1% to 5%)							
Standard Features	Back Feed protection and splitted bypass line							
OUTPUT								
Power (kVA)	100	120	160	200	250	300	400	500
Active Power (kW)	80	96	128	160	200	270	360	450
Nominal Voltage (V)	380-400-415Vac 3phase							
Static Stability	± 1%							
Dynamic Stability	± 5% in 10msec							
Voltage Distortion	< 1% at linear load / < 3% at non-linear load							
Crest Factor	3:1							
Frequency stability on battery mode	0.05%							
Frequency	50 - 60 Hz (selectable)							
Overload Control	110% for 60min.; 125% for 10min.; 150% for 1min.							
BATTERIES								
Type	Pb Selead acid, Wet, Ni-Cd							
Ripple	< 1%							
Temperature Compens.	-500mV x °C							
Typical charging current	0,2 x C10							
N. cells for Pb Batteries	240							
COMMUNICATION								
Standard	Double RS232 ports with Monitoring Software CD; Dry contacts (selectable); 2 interface intellislots							
Remote Commands	EPO and INV. OFF							
Optional	SNMP card; JBUS/ModBUS converter RS485 port; ProfiBUS converter; Multilicence							
ENVIRONMENTAL								
Room Temperature	0 ÷ 40 °C							
Humidity	< 95% (non-condensing)							
Compliance	Standards LV 2006/95/EC - 2004/108/EC - Safety IEC EN 62040-1; EMC IEC EN 62040-2; Performance IEC EN 62040-3; VFI-SS-111 Classified as IEC 62040-3							

**Note:** product specifications are subject to change without further notice.

# LIBRA<sup>PRO</sup>

TECHNICAL SPECIFICATIONS						
<b>Model</b>	LB100TP	LB120TP	LB160TP	LB200TP	LB600P12	LB800P12
Rated Power (kVA)	100	120	160	200	600	800
Efficiency	> 93% in AC/AC; up to 98% in Smart Active Mode					
Dimension (mm) LxDxH	800x800 x1900	800x800 x1900	800x800 x1900	800x800 x1900	3200x 980x1900	4400x1000 x1900
Weight (kg) w/o batteries	640	650	770	810	4000	5300
Colour	Light Gray RAL 7035 (or RAL7016 on request)					
Protection Rating	IP20					
Noise (dB at 1m)	63 ÷ 68				74 ÷ 77	
INPUT						
Rectifier Technology	6 Pulse	6 Pulse	6 Pulse	6 Pulse	12 Pulse	12 Pulse
Rated Voltage	380-400-415Vac 3ph					
Voltage Tolerance	300 ÷ 480 Vac				320 ÷ 480 Vac	
Frequency	45 ÷ 65 Hz					
Power walk-in	0 ÷ 100% in 30sec. (selectable)					
Frequency Tolerance	± 2% (selectable from 1% to 5%)					
Standard Features	Back Feed protection and splitted bypass line					
OUTPUT						
Power (kVA)	100	120	160	200	600	800
Active Power (kW)	90	108	144	180	480	640
Nominal Voltage (V)	380-400-415Vac 3phase					
Static Stability	± 1%					
Dynamic Stability	± 5% in 10msec					
Voltage Distortion	< 1% at linear load / < 3% at non-linear load					
Crest Factor	3:1					
Frequency stability on battery mode	0.05%					
Frequency	50 - 60 Hz (selectable)					
Overload Control	110% for 60min.; 125% for 10min.; 150% for 1min.					
BATTERIES						
Type	Pb Selead acid, Wet, Ni-Cd					
Ripple	< 1%					
Temperature Compens.	-500mV x °C					
Typical charging current	0,2 x C10					
N. cells for Pb Batteries	198				240	
COMMUNICATION						
Standard	Double RS232 ports with Monitoring Software CD; Dry contacts; 2 interface intellislots					
Remote Commands	EPO and INV. OFF					
Optional	SNMP card; JBUS/ModBUS converter RS485 port; ProfiBUS converter; Multilicence					
ENVIRONMENTAL						
Room Temperature	0 ÷ 40 °C					
Humidity	< 95% (non-condensing)					
Compliance	Standards LV 2006/95/EC - 2004/108/EC - Safety IEC EN 62040-1; EMC IEC EN 62040-2; Performance IEC EN 62040-3; VFI-SS-111 Classified as IEC 62040-3					

Available also with input filter for CLEAN version.

**Note:** product specifications are subject to change without further notice.

**G-Tec Companies** are also present worldwide with Business Partners in several countries.

**G-Tec Europe Srl** in Vicenza - Italy

**G-Tec Asia Pacific Pte Ltd** in Singapore



**G-Tec Europe srl**

Strada Marosticana, 81/13 - 36031 Povolara (VI), Italia  
Tel. +39 0444.361321 - Fax +39 0444.365191  
info@gtec-power.eu

**G-Tec Asia Pacific Pte Ltd**

60 Kaki Bukit Place, #02-05, Eunos Techpark II, Singapore 415979  
Tel. +65 6555.5014 - Fax +65 6555.4105  
info@gtec.com.sg

[www.gtec-power.eu](http://www.gtec-power.eu)